

High Definition FlexMic™ Series



FMRHD Series: Gooseneck with Rigid Center and Flex at Both Ends, available in three lengths

FMHD Series: Fully Flexible Gooseneck, available in two lengths



- 40kHz High Frequency Response
- Spectacular Intelligibility & Sound Quality
- On or Off Axis, Always Hear the Orator
- Uniform Frequency Response at 0°, 45° & 90°
- More Gain Before Feedback
- No Handling Noise
- 139dB SPL Max Acoustic Input
- Excellent RFI Rejection
- Available in Cardioid or Hypercardioid
- Available with Fully Flexible Gooseneck in Short or Medium Lengths
- Available with Rigid Center Gooseneck with flex at both ends, in Short, Medium or Long Lengths
- Optional PMM1 Podium Mount Accessory

"When we use the new HD FlexMic for our worship services, here is what we notice: (1) there is a phenomenal clarity in the sound (almost like there was no microphone there at all), (2) the intelligibility is incredible, and (3) it has mic has a much further reach both on and off-axis."

Franklin Denham, Minister of Music, Highland Baptist Church, Meridian MS

The new Earthworks High Definition FM Series offers spectacular results and will outperform any other podium microphone at any price. The FMHD microphones will allow you to hear more detail with greater clarity than previously possible. Just plug one into the XLR connector on a podium and you will find the audible results absolutely incredible. The new FMHD podium microphones are the perfect choice for those who demand only the very best and are ideal for use in civic centers, boardrooms, educational facilities, theatres, churches and houses of congress.

Earthworks patented technologies provide high intelligibility and uniform off-axis response to ensure that the orator is always heard and well understood at the front, at the sides, below or above the microphone. This smooth off-axis response also provides more gain before feedback and an incredible 32dB rejection of sounds behind the microphone. With 139dB SPL max acoustic input, it is virtually impossible to overload the microphone and there is no microphone handling, noise in addition to incredible RFI rejection.

The Earthworks FMHD Series models offer you a variety of choices with fully flexible goosenecks or goosenecks with rigid centers that have flex at both ends. All models are available in either cardioid or hypercardioid polar patterns. The optional PMM1 podium mount will work with any FlexMic™ Series model. If you haven't heard an Earthworks High Definition FlexMic™, you are in for a real surprise!

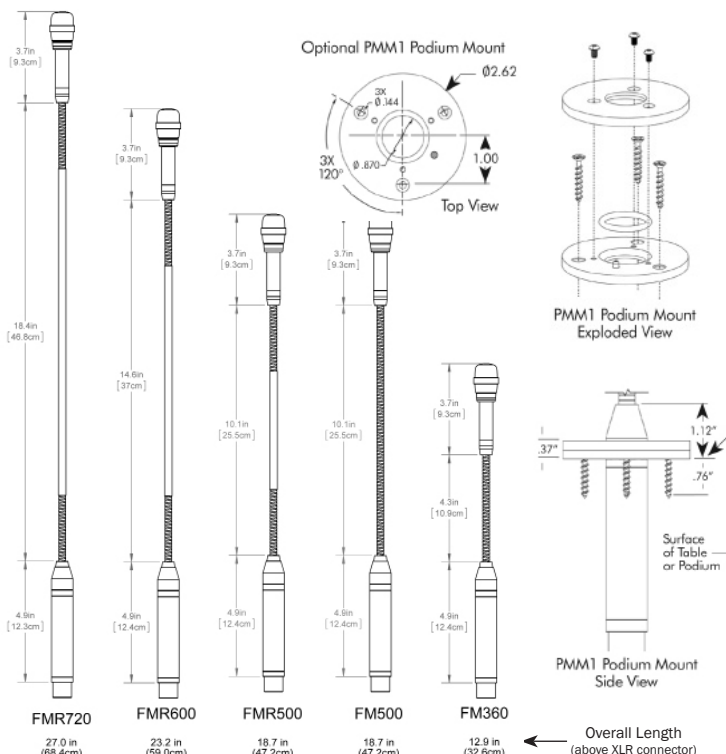

See full specifications on back of page

SPECIFICATIONS

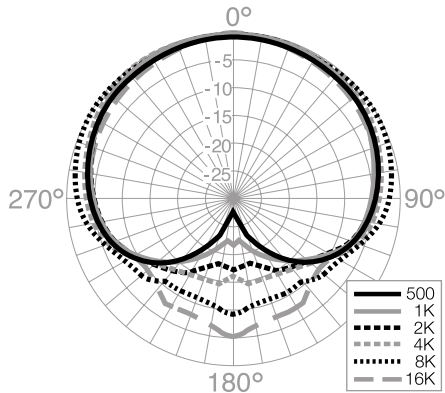

Typical Cardioid Polar Response

Above polar applies to all Cardioid models in the FM and FMR Series

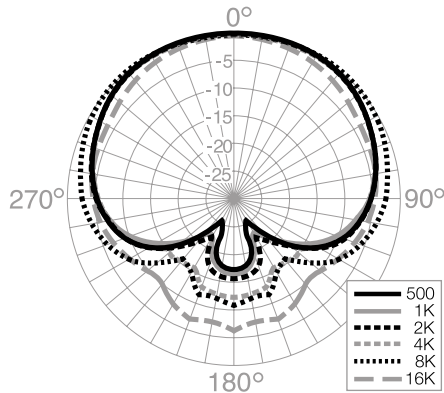

Typical Hypercardioid Polar Response

Above polar applies to all Hypercardioid models in the FM and FMR Series

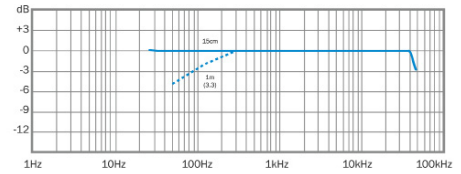

Frequency Response

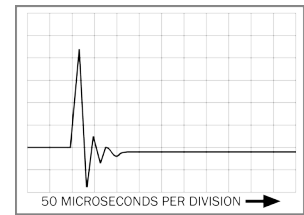

Impulse Response

Above graphs apply to all cardioid and hypercardioid models in the FM and FMR Series

FMHD Series Gooseneck with Rigid Center and Flex at both ends

FM360HD & FM500HD
FM360HD/HC & FM500HD/HC

Specifications

Frequency Response: 50Hz to beyond 40kHz \pm 2dB @ 12 in.
Polar Pattern: Cardioid or Hypercardioid
Sensitivity: 20mV/Pa (-34dBV/Pa)
Power Requirements: 48V Phantom, 10mA
Max Acoustic Input: 139dB SPL
Connector: XLR-3 (pin 2+)
Min Output Load: 600 ohms between pins 2 & 3
Noise: 16dB SPL equivalent (A weighted)
Gooseneck: Fully flexible gooseneck
Diameter .275 in. (7mm)
Dimensions: Base diameter is .860" (22mm)
Lengths: FM360 12.5in. (31.8cm) & FM500 18.3in. (46.5cm)
Weight: 0.3 lb. (137g)

Architectural & Engineering Specifications

The microphone shall be a back-electret condenser type with a wide-range uniform frequency response of 50 Hz to 40 kHz \pm 2 dB. The microphone shall have an output level of 10 mV/Pa. The microphone shall be of a single capsule, single membrane design. The microphone shall have an impulse response with the rise time no longer than 25 microseconds, and total settling time, including the rise time, no longer than 120 microseconds. The microphone shall have polar characteristics uniform in all planes to form either a cardioid or hypercardioid of revolution. Response at any angular position up to 90° away from the major axis within frequency range from 500 Hz to 16 kHz shall deviate by no more than \pm 3 dB from the ideal cardioid or hypercardioid pattern as described by the following equation: $SPL(a) = 20 \cdot \log(1/2 + \cos(a)/2)$ (dB), where a is the angle in radians between the measurement source position axis and the major axis. The microphone shall accept sound pressure levels up to 139 dB producing no more than 3% THD. Overall length above the XLR connector shall be 12.5 in. (31.8cm) long for FM360HD and 18.3 in. (46.5cm) long for the FM500HD. The maximum head diameter shall be 1.0 in. (25 mm). The microphone shall be terminated with a professional gold-plated 3 pin XLR connector. The microphone shall include an external windscreen. The microphone shall require 48V phantom power. The microphone shall be made of metal with black finish. The microphone shall have its entire flexible portion encased in black vinyl. The Earthworks FM360HD, FM500HD cardioid or FM360HD/HC, FM500HD/HC hypercardioid is specified.

FMRHD Series Gooseneck with Rigid Center and Flex at both ends

FMR500HD, FMR600HD & FMR720HD
FMR500HD/HC, FMR600HD/HC & FMR720HD/HC

Specifications

Frequency Response: 50Hz to beyond 40kHz \pm 2dB @ 12 in.
Polar Pattern: Cardioid or Hypercardioid
Sensitivity: 20mV/Pa (-34dBV/Pa)
Power Requirements: 48V Phantom, 10mA
Max Acoustic Input: 139dB SPL
Connector: XLR-3 (pin 2+)
Min Output Load: 600 ohms between pins 2 & 3
Noise: 16dB SPL equivalent (A weighted)
Gooseneck: Rigid center with 2.5in. to 3in. flex on both ends
Diameter .316 in. (8mm)
Dimensions: Base diameter is .860" (22mm)
Lengths: FMR720 26.6 in. (67.6cm), FMR600 22.8 in. (58cm), FMR 500 18.3 in. (46.5cm)
Weight: 0.3 lb. (137g)

Architectural & Engineering Specifications

The microphone shall be a back-electret condenser type with a wide-range uniform frequency response of 50 Hz to 40 kHz \pm 2 dB. The microphone shall have an output level of 10 mV/Pa. The microphone shall be of a single capsule, single membrane design. The microphone shall have an impulse response with the rise time no longer than 25 microseconds, and total settling time, including the rise time, no longer than 120 microseconds. The microphone shall have polar characteristics uniform in all planes to form either a cardioid or hypercardioid of revolution. Response at any angular position up to 90° away from the major axis within frequency range from 500 Hz to 16 kHz shall deviate by no more than \pm 3 dB from the ideal cardioid or hypercardioid pattern as described by the following equation: $SPL(a) = 20 \cdot \log(1/2 + \cos(a)/2)$ (dB), where a is the angle in radians between the measurement source position axis and the major axis. The microphone shall accept sound pressure levels up to 139 dB producing no more than 3% THD. Gooseneck will have a rigid center section with flexible gooseneck at both ends. Overall length above the XLR connector shall be 18.3 in. (46.5cm) long for FMR500HD, 22.8 in. (58cm) long for FMR600HD and 26.6 in. (67.6cm) long for the FMR720HD. The maximum head diameter shall be 1.0 in. (25 mm). The microphone shall be terminated with a professional gold-plated 3 pin XLR connector. The microphone shall include an external windscreen. The microphone shall require 48V phantom power. The microphone shall be made of metal with black finish. The Earthworks FMR500HD, FMR600HD or FMR720HD cardioid or FMR500HD/HC, FMR600HD/HC or FMR720HD/HC hypercardioid is specified.

Earthworks' sleek new metal windscreen design makes the FM and FMR series podium microphones more attractive and more durable than ever before!



Perfect for:

- Performance Art Centers
- Corporate Boardrooms
- Educational Facilities
- Civic Centers
- Stadiums
- Courtrooms
- Congress



Earthworks FlexMics™ Series have been chosen for use in premium church installations, houses of congress, court rooms, political debates, corporate boardrooms, universities and other educational and governmental institutions.

Specifications Subject to Change without Notice

