

- High Definition Microphones™ for Conference Rooms and Fixed Sound Installations
- Near-perfect Polar Response (uniform frequency response at 0°, 45° & 90°)
- Can be Mounted in Wall, Ceiling or Conference Tables (includes lock nut)
- High Rejections of Sounds from the Rear of the Microphone
- Very High Intelligibility
- More Gain Before Feedback
- 30Hz to 30kHz Frequency Response
- Very Easy to Position via Mini-gooseneck
- 145dB Max Acoustic Input
- Requires 48V Phantom Power
- Available in Black, White or Silver

**High Definition Microphones™ for Fixed Installations**

The Earthworks IM Series™ High Definition Microphones™ provide astounding audio quality for fixed installations. The IM Series™ can be custom mounted in a ceiling, wall or table and will provide the ultimate in sound quality, flexibility and ease of installation. The IM microphone's uniquely designed small head and flexible mini-gooseneck allow it to be easily and precisely positioned. The IM Series™ near-perfect polar response will not beam or spotlight and will provide very high intelligibility. The frequency response of both the cardioid or hypercardioid at 90 degrees off-axis is within 2dB of the on-axis response (over its operating frequency range). This overall uniform frequency response of the hypercardioid is at least 5dB down at 90 degrees off-axis. This exceptional polar response allows the use of fewer microphones, while obtaining higher intelligibility and more gain before feedback.

**Near-Perfect Polar Response**

David Blackmer invented a number of new microphone technologies resulting in a totally new approach to microphone design. One such technology resulted in the creation of near-perfect polar patterns. When you look at a polar pattern of an Earthworks microphone, the mid-frequencies, high-frequencies and low-frequencies all look very close to a "text-

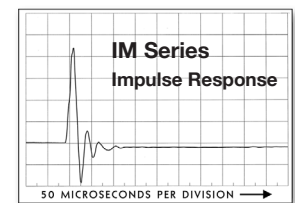
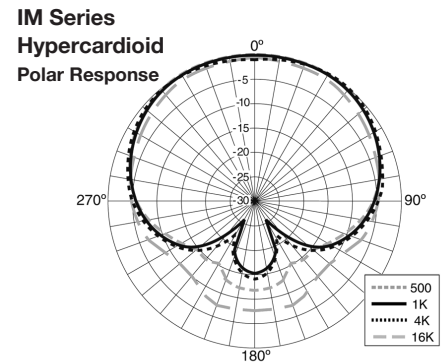
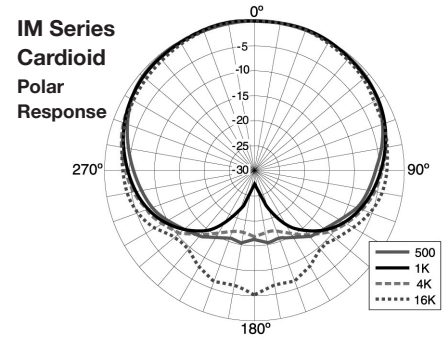

book" polar pattern. In practice this means the polar response of an Earthworks microphone is extremely uniform over its operating frequency range; the frequency response at 90 degrees off-axis is very close to the on-axis response. This uniform polar response results in less phase problems and much higher intelligibility at the sides of the microphone.

**IM Series™ Installation Microphones**

The IM Series™ provides a low profile, pristine sounding microphone solution for permanent installations. Featuring a flat frequency response and patented polar technology, orators will maintain the same intelligibility throughout the room without a reduction of sound level or loss of high frequencies, while obtaining more gain before feedback. The IM Series™ installation microphones provide a 30Hz to 30kHz frequency response, near-perfect polar response with pristine audio in an attractive low-profile package with options of 3, 6, 10 or 12 inch mini-goosenecks in black, white or silver.

Specifications & Dimensions are on back of this page

**Architectural & Engineering Specifications**  
**30kHz Cardioid**

The microphone shall be a back-electret condenser type with a wide-range uniform frequency response of 30 Hz to 30 kHz  $\pm 2$ dB and shall have an output level of 10mV/Pa. The microphone shall be of a single capsule, single membrane design with an impulse response rise time no longer than 25 microseconds, and total settling time, including rise time, no longer than 120 microseconds. The microphone shall have polar characteristics uniform in all planes to form a cardioid or hypercardioid of revolution and shall accept sound pressure levels up to 145dB producing no more than 3%THD. Dimensions of the microphone bodies shall be 4.495 in. (114mm) long by .920 in. (23mm) in diameter. Gooseneck lengths, respective of model shall be; IM3: 3 in. (76mm), IM6: 6 in. (152mm), IM10: 10 in (254mm), and the IM12: 12 in. (305mm). The maximum head diameter shall be .540 in. (14mm). The microphone body threading shall use the NPT standard of 1.660 in. (42.16mm) outer diameter 0.08696 in. (2.20878mm) thread pitch. The microphone shall be terminated with a male XLR-3 connector and shall require 48V phantom power. The microphone shall be made of metal with choice of finish. The Earthworks IM3, IM6, IM10 or IM12 (in black, white or silver) is specified.



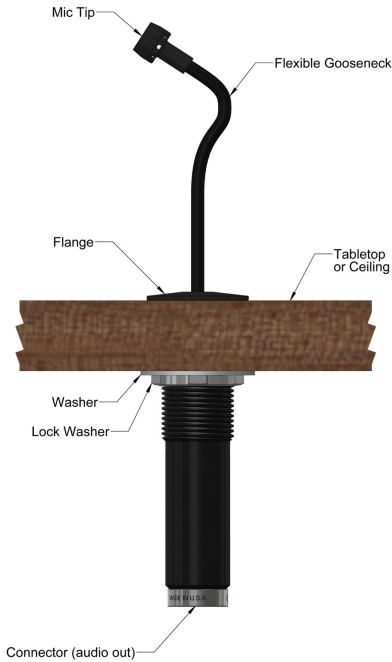

Special Order Options include custom microphone colors and custom gooseneck lengths.

## IM SERIES SPECIFICATIONS

**Frequency Response:** 30Hz to 30kHz ± 2dB @ 1 ft. (30cm)

**Polar Pattern:** Cardioid

**Sensitivity:** 10mV/Pa (-40dBV/Pa)

**Power requirements:** 48V Phantom, 10mA

**Max Acoustic Input:** 145dB SPL

**Output:** XLR-3 (pin 2+)

**Min. Output Load:** 600 ohms between pins 2 & 3

**Noise:** 22dB SPL (A weighted)

**Dimensions:** See drawings at right

**Color:** Black, White or Silver

**Weight:** 0.28 lbs. (125g)

### IM3 Dimensions (available in black, white or silver)

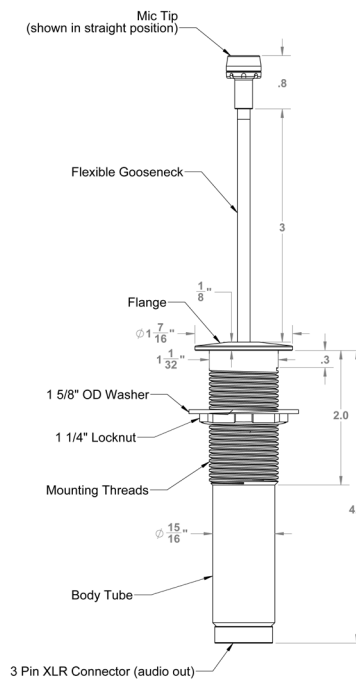

### IM6 Dimensions (available in black, white or silver)

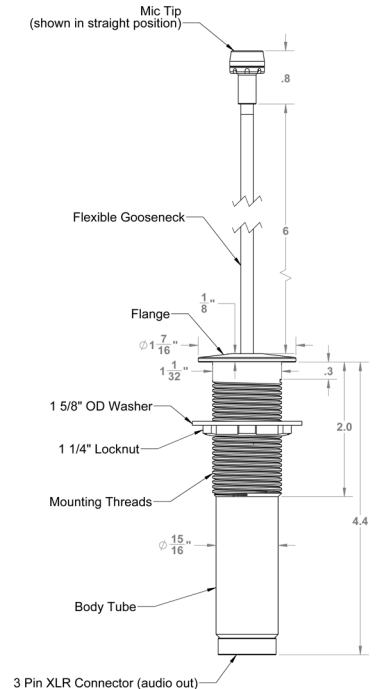

### IM10 Dimensions (available in black, white or silver)

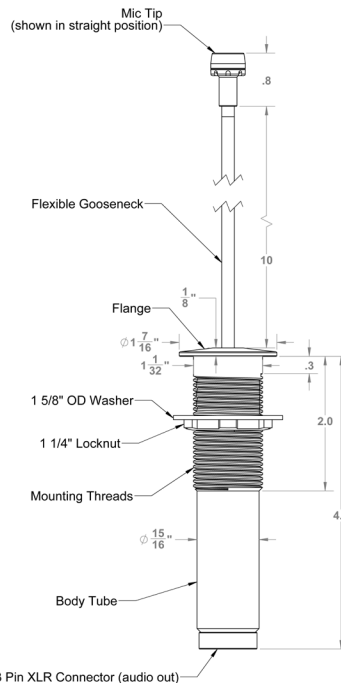

### IM12 Dimensions (available in black, white or silver)

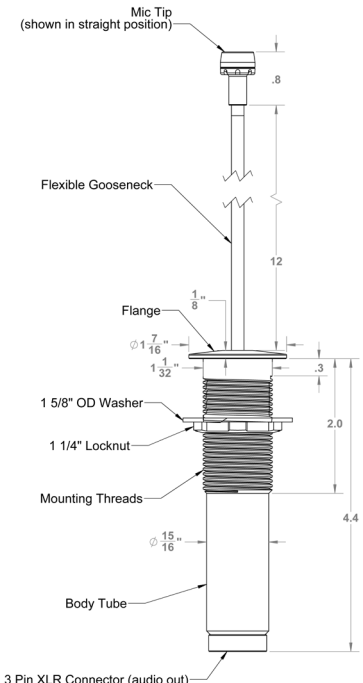

Specifications Subject to Change without Notice